

# Immersible directly into the foaming liquid Simple to handle solid silicone defoamer

## AWA CATCHER™

AWA CATCHER, a solid-type silicone defoamer, is a solid-type defoamer that is easier to handle than an emulsion-type defoamer. It can be used in a wide range of industrial applications, including wastewater treatment.

### 1 Features

The characteristics of AWA CATCHER are as follows.

Solid type	<ul style="list-style-type: none"> <li>This is a solid-type product formed by blending silicone defoaming components with emulsifying components that have melting points above room temperature.</li> <li>The defoaming component is gradually dispersed by directly immersing into the water-based foaming liquid, and the defoaming effect is sustained.</li> </ul>
Simple to handle	<ul style="list-style-type: none"> <li>The work is completed simply by immersing the AWA CATCHER directly into the foam. After charging, the active ingredient gradually spreads into the foaming liquid, and the defoaming effect usually lasts for about 2 weeks*</li> <li>It does not need to be diluted like an emulsion-type antifoaming agent, and no addition equipment or maintenance is required.</li> </ul> <p><small>*The antifoaming effect depends on the type and condition of the foaming liquid. Perform the test beforehand.</small></p>
Quality assurance period is 1 year	<ul style="list-style-type: none"> <li>The AWA CATCHER has 1 year quality assurance period after shipment, whereas general emulsion-type antifoam have only 3 months.</li> </ul>
Environment-friendly package	<ul style="list-style-type: none"> <li>The package of the product is a paper container, and no plastic waste is discharged.</li> </ul>

### 2 Uses

- Wastewater treatment
- Cyclic water treatment such as scrubbers

### 3 General Properties

Product name		AWA CATCHER
Item		
Appearance		White solid
Melting point	°C	53
Active ingredient	%	100

(Not specified values)

### 4 Shape

- Size: About 7cm of upper side × about 8cm of lower side × about 3.5cm of height
- Weight: 200g

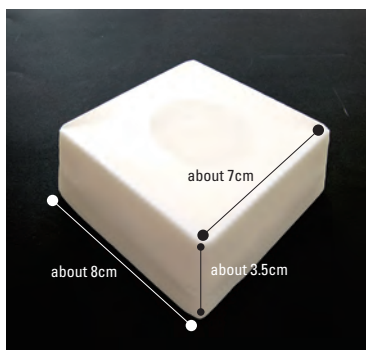





### 5 Package/unit of sales

- Package: Paper container
- Sale units: 200g × 10 per case, 200g × 20 per case

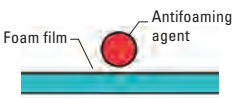

### 6 Defoaming mechanism

The defoaming mechanism of AWA CATCHER is as follows.

<p>[1] Dispersion of antifoam ingredients</p>		<p><b>Have dispersibility with the foaming liquid</b></p> <p>The defoaming component of the AWA CATCHER gradually disperses into the foaming liquid and adheres to the foam film (the film on the part where the foaming liquid is foamed) (if the water flow is weak, the dispersion becomes insufficient, and the defoaming effect may not be obtained)</p>
<p>[2] Antifoaming agent component adheres to foam film</p>		
<p>[3] Antifoaming agent components penetrate into foam film</p>		<p><b>Hardly dissolve in the foaming solution</b></p> <p>The defoaming component adhering to the foam film does not dissolve but enters into the foam film (if the defoaming component dissolves in the foam solution, the foam film stabilizes and becomes a factor of foaming)</p>
<p>[4] Antifoaming ingredient expanded on foam</p>		<p><b>Have a lower surface tension than the foaming liquid</b></p> <p>The defoaming component that has penetrated into the foam film is pulled to the high surface tension of the foam film and expands, and the foam film is broken (if the surface tension of the defoaming component is higher than that of the foam film, the defoaming performance becomes worse.)</p>
<p>[5] Antifoaming agent component breaks foam</p>		

### 7 Comparison by product type

Comparison with emulsion type defoamer and conventional solid type defoamer is as follows.

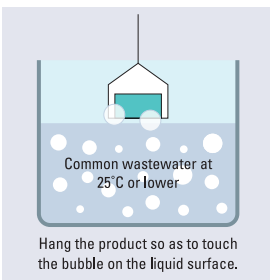
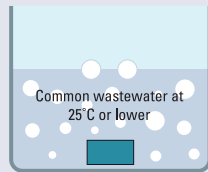
Product type	Emulsion antifoam	Solid antifoam / KM-601S	New solid antifoam / AWA CATCHER
<p>Directions for use</p>	 <p>Use diluted with the foaming liquid to be defoamed</p> <ul style="list-style-type: none"> <li>Dilution and adjustment are required by calculating the amount added each time. (Continuous dripping is required.)</li> </ul>	 <p>Common wastewater at 25°C or lower</p> <p>Hang the product so as to touch the bubble on the liquid surface.</p> <p>Suspended in contact with bubbles on the liquid surface</p> <ul style="list-style-type: none"> <li>Maintenance free (Suspend if lost)</li> </ul>	 <p>Common wastewater at 25°C or lower</p> <p>Immersing into foaming liquid</p> <p>Use by direct injection into the liquid</p> <ul style="list-style-type: none"> <li>Maintenance free (input [standard: 2 weeks] when it is eliminated.)</li> </ul>
<p>Defoaming effect</p>	<p>Fast-acting: ○, persistent: △ or ×</p>	<p>Fast-acting: ○, persistent: △ (shows effect when touching foaming liquid)</p>	<p>Fast-acting: △, persistent: ○ (shows effect when dispersed in foaming liquid)</p>
<p>Waste materials</p>	<p>Cans, paper cartons, plastic bottle, etc.</p>	<p>Plastic bag only</p>	<p>Paper container only (environmentally friendly)</p>
<p>Warranty Period</p>	<p>3 months after delivery (general case)</p>	<p>3 months after delivery</p>	<p>1 year after delivery</p>
<p>Point of use</p>	<p>The defoaming effect is greatly reduced with the inflow and outflow of the foaming liquid. Therefore, it is necessary to add a defoaming agent from time to time.</p>	<p>Effects are sustained for a certain period of time due to the elution of defoaming ingredients. (Depending on the environment and conditions of use, replacement may be required in a few days if immersed into foaming liquid.)</p>	<p>Suitable for use in conditions where there is constant water flow. If there is no flow at all, sufficient defoaming effect may not be obtained.</p>

### 8 Results of the defoaming test

• Test method

Taking into account the common wastewater application, a defoaming test was carried out while the foaming liquid 500mL was drawn at every 5 minutes from the beginning of the test and replaced with a new foaming liquid.

Item	Product name	AWA CATCHER
Test method		Circulation test method
Foaming liquid		0.1% detergent aqueous solution
Volume of foaming liquid	mL	1,800
Flow rate	L/min	3
Amount of sample	g	3

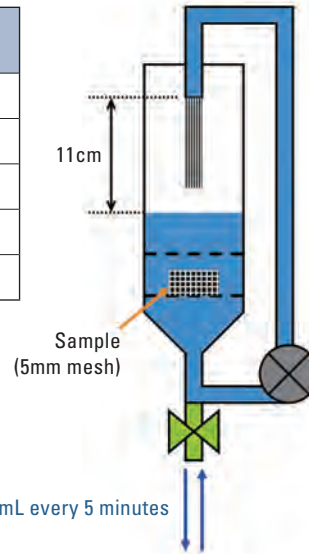

Replace foaming liquid 500mL every 5 minutes

• Test results

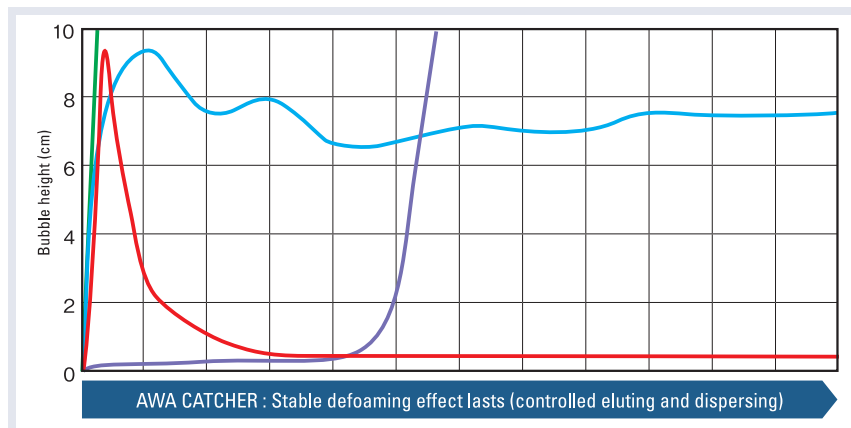

Tested samples

- KM-601S (solid / suspended)
- KM-73 (general-purpose emulsion)
- AWA CATCHER (solid / immersing)
- blank

AWA CATCHER : Stable defoaming effect lasts (controlled eluting and dispersing)

### 9 Various wastewater tests

The results of various wastewater tests are as follows.

Parameter	Product name	Test results	Test method
BOD	mg/L	210	JIS K0102 21 and 32.3 diaphragm electrodes
COD(Mn)	mg/L	210	JIS K0102 17 100°C KMnO process
COD(Cr)	mg/L	720	Potassium JIS K0102 20 dichromate method
n-hexane extract (mineral oil)	mg/L	< 5	Sewage test method Part 2, Chapter 2, Section 40
n-hexane extract (animal and vegetable oil)	mg/L	79	Sewage test method Part 2, Chapter 2, Section 40

(Not a standard)

### 10 Activated sludge respiration inhibition testing

The results of the activated sludge respiration inhibition test are as follows.

Test Content	Test results	Remarks
50% respiratory inhibitory level EC <sub>50</sub> (3h).	> 1,000mg/L	Concentration of the test substance at which the microbial respiration rate is subject to 50% inhibition. Actually, adding 1000ppm does not inhibit your respiration very much.

\*The results of the activated sludge respiration inhibition test are representative of the measurements made on a specific batch only and do not guarantee all batches.

## 11 Points of testing in advance

If you would like to test the AWA CATCHER in advance, please refer to the following points to evaluate it.

Parameter	Points
Input point	Trial effects at multiple locations (e.g., areas with high water flow, areas with low water flow, etc.).
Input method	By putting a string in a net, etc., the status of the product can be checked, and the input position can not be shifted.
Amount used	The appropriate number of AWA CATCHER is affected by the size of the tank and the water flow, but using one or two is the standard.
Timing of evaluation	Since defoaming component are gradually dispersed in the foaming liquid, evaluation should be made after a certain amount of time has elapsed, not immediately after immersion.

## 12 Precautions when using

- 1) AWA CATCHER exhibit defoaming properties by dispersing the defoaming component in the foaming liquid, and therefore, in a situation where there is no flow at all, dispersibility is reduced, and it may be difficult to obtain a defoaming effect. Use the product where always water flows, such as aeration tank or septic tank.
- 2) When using in a situation where the inflow and outflow of the foaming liquid are repeated, the emulsion type antifoam flows out together with the foaming liquid, so the defoaming effect decreases, and the addition of the antifoam is required. In the case of an AWA CATCHER, it is not required additional immersion, because it is solid and gradually disperses.

## 13 Handling Precautions

- 1) Store in a dry place away from sparks and open flame.
- 2) AWA CATCHER may melt at high temperatures, so be sure to keep it in a cool, dark place.

## 14 Safety and Hygiene

- 1) When using this product, take care to prevent contact with the skin and mucous membranes. In case of contact, wash immediately and thoroughly with soap and water or plain running water.
- 2) In case of eye contact, flush immediately with clean water for at least 15 minutes and then seek medical attention.
- 3) Keep out of reach of children.
- 4) Please read the Safety Data Sheet (SDS) before use. SDS can be obtained from our Sales Department.

•The data and information presented in this catalog may not be relied upon to represent standard values. Shin-Etsu reserves the right to change such data and information, in whole or in part, in this catalog, including product performance standards and specifications without notice.

•Users are solely responsible for making preliminary tests to determine the suitability of products for their intended use. Statements concerning possible or suggested uses made herein may not be relied upon, or be construed, as a guaranty of no patent infringement.

•For detailed information regarding safety, please refer to the Safety Data Sheet (SDS).

•The silicone products described herein have been designed, manufactured and developed solely for general industrial use only; such silicone products are not designed for, intended for use as, or suitable for, medical, surgical or other particular purposes. Users have the sole responsibility and

obligation to determine the suitability of the silicone products described herein for any application, to make preliminary tests, and to confirm the safety of such products for their use.

- Users must never use the silicone products described herein for the purpose of implantation into the human body and/or injection into humans.
- Users are solely responsible for exporting or importing the silicone products described herein, and complying with all applicable laws, regulations, and rules relating to the use of such products. Shin-Etsu recommends checking each pertinent country's laws, regulations, and rules in advance, when exporting or importing, and before using the products.
- Please contact Shin-Etsu before reproducing any part of this catalog. Copyright belongs to Shin-Etsu Chemical Co., Ltd.



<https://www.shinetsusilicone-global.com/>

**Shin-Etsu Chemical Co., Ltd.**

Marunouchi Eiraku Bldg., 4-1, Marunouchi 1-chome,  
Chiyoda-ku, Tokyo, 100-0005 Japan

**Silicone Division, Sales and Marketing Department II**

Phone : +81-(0)3-6812-2407 Fax : +81-(0)3-6812-2414